

1 Ton Jumbo Bag Weighing System

IPMA INDUSTRY SDN. BHD.

益马工业有限公司

198501004398 (136837-P)



Model: ITW-1000

G.I. Packing Bin

c/w top cover, bracket and high stand.



Weighing bin
c/w pneumatic shutters



Weigher panel

c/w colour touch screen, digital weighing indicator and PLC control.

www.ipmaindustry.com

Details provided about the properties and usability of the products are purely for information purposes and do not constitute a guarantee of these characteristics. The extent of goods delivered and services performed is determined by the subject matter of the specific contract. No liability accepted for errors or omissions.

IPMA

Your One Stop Rice Processing And Solution Centre!



Technical Specification

1 Ton Jumbo Bag Weighing System

Model: 1TW-1000

TOP VIEW

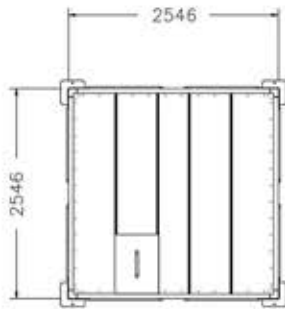

ISOMETRIC VIEW

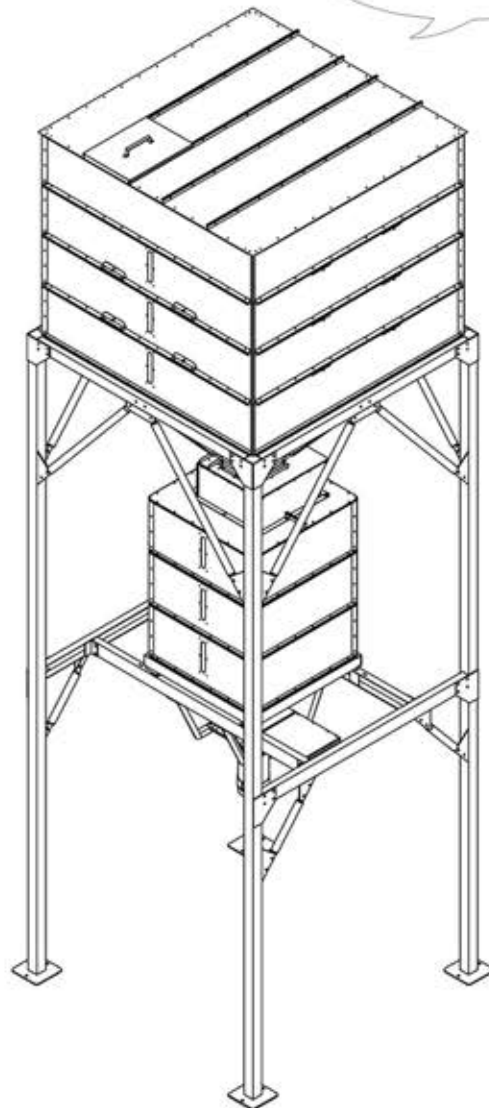

FRONT VIEW

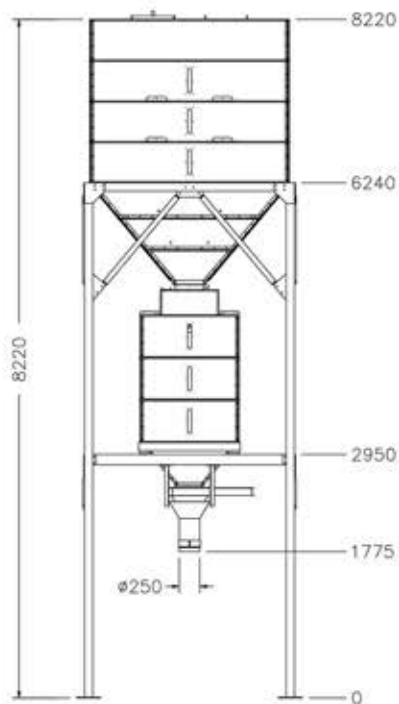

Model	Output Capacity	Dimension(MM) (L x W x H)
1TW-1000		2546 x 2546 x 8220

