

# Paddy Precleaner

IPMA INDUSTRY SDN. BHD.

益马工业有限公司

198501004398 (136837-P)



Model : PC-50 / PC-60 / PC-70



Model : PC-70

Model : PC-60

Model : PC-50

## OUTPUT



Paddy  
(Accept)



Straw



Husk /  
Immatured Grain



Straw(Short)



Coarse Bran

## OUTSTANDING FEATURES

1. Using combination of air and perforated screen for more efficient cleaning.
2. Removal of straw and rubble by large diameter rotating drum, followed by a 'nose' screen to recover kernels from the straw.
3. Grains are equally divided into 2 sieve boats to produce high capacity cleaning.
4. Light impurities are removed by both pre and post aspiration system.
5. Sieve boats are counterbalanced to give the machine quiet and vibrating free operation and all screens are fitted with rubber balls which keep the perforations clean for optimum performance

[www.ipmaindustry.com](http://www.ipmaindustry.com)

Details provided about the properties and usability of the products are purely for information purposes and do not constitute a guarantee of these characteristics. The extent of goods delivered and services performed is determined by the subject matter of the specific contract. No liability accepted for errors or omissions.

# IPMA

Your One Stop Rice Processing And Solution Centre!



# Technical Specification

## Paddy Precleaner

Model: PC-50 / PC-60 / PC-70

TOP VIEW

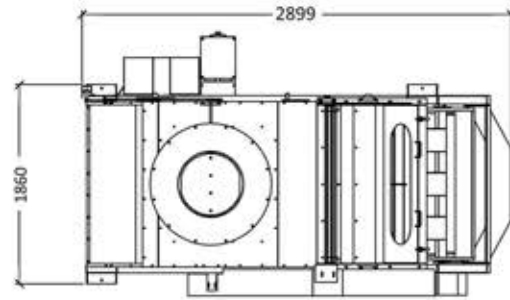

TOP VIEW

FRONT VIEW

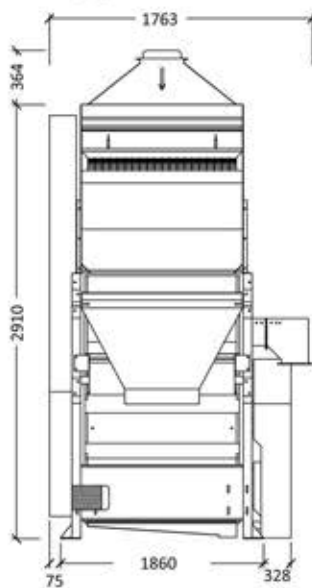

FRONT VIEW

SIDE VIEW

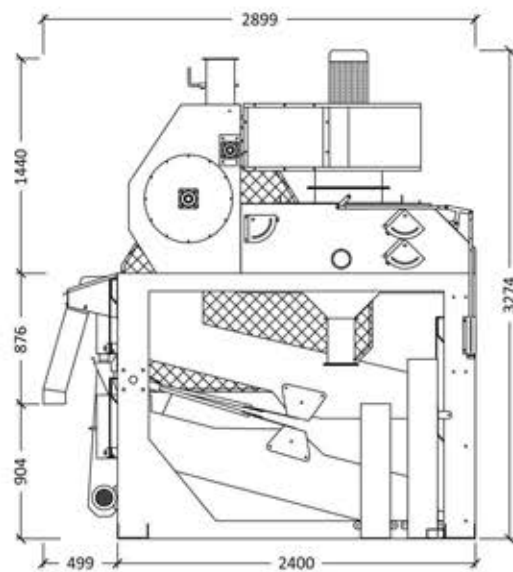

SIDE VIEW

Model	Power Requirement	Output Capacity	Screen Size 4 Layers	Air Volume	Weight	Dimension(MM) (L x W x H)
PC-50	1.5+5.5 KW	5-10 T/H	1000 x 2000 MM	12500 M <sup>3</sup> /H	1750 KG	2898 x 1763 x 3274
PC-60	1.5+7.5 KW	10-15 T/H	1250 x 2000 MM	13500 M <sup>3</sup> /H	1900 KG	2898 x 2013 x 3274
PC-70	1.5+7.5 KW	15-20 T/H	1500 x 2000 MM	13500 M <sup>3</sup> /H	2100 KG	2898 x 2263 x 3274



ISO 9001 : 2015  
Approval No : 0048394