

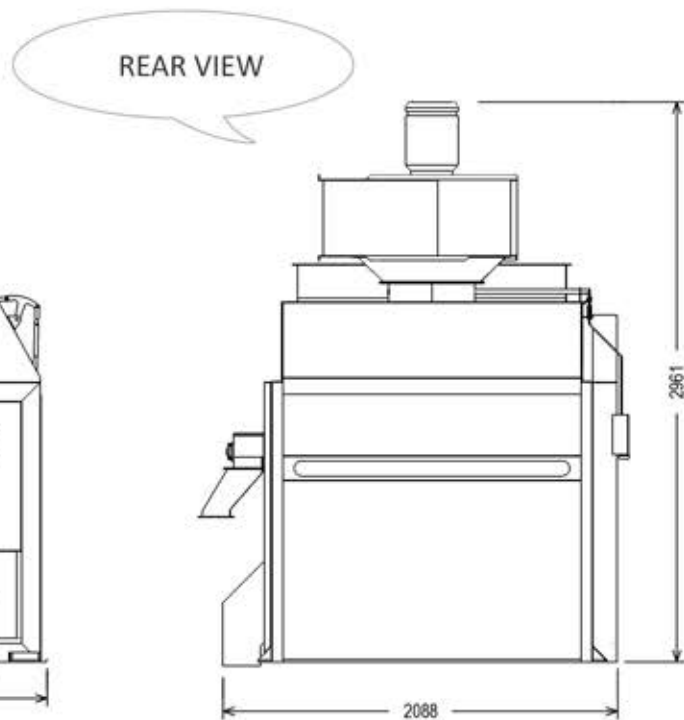

Technical Specification

Precleaner with Pre Suction Aspirator and Straw Scraper System

Model: SAB-A-S-1500

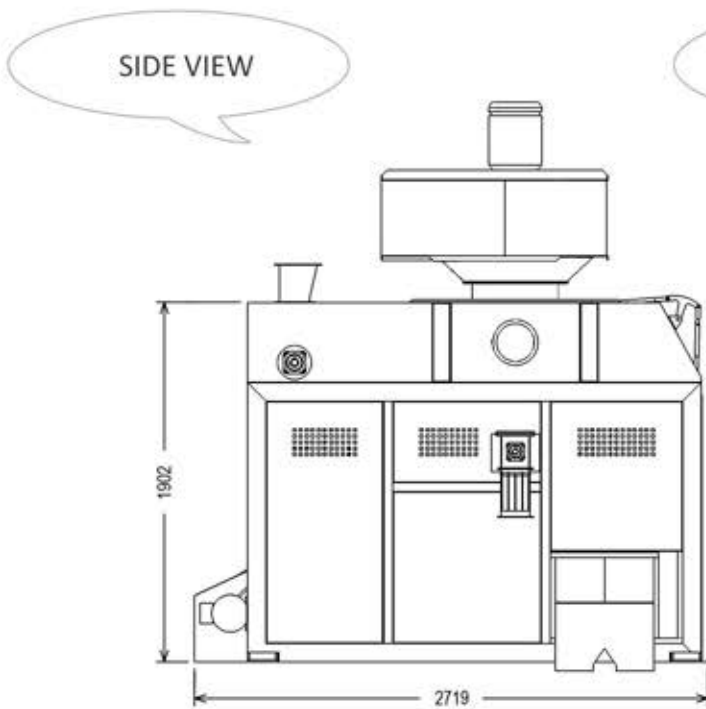
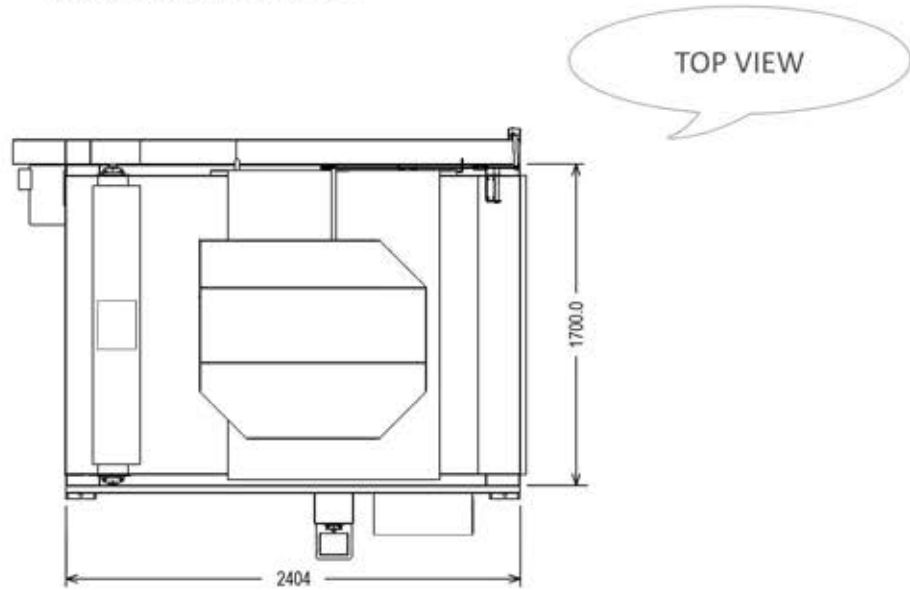

Model	Power Requirement	Capacity	Screen Width 2 layers	Weight	Dimension(MM) (L x W x H)
SAB-A-S-1500	7.5 kw + 1.5 kw + 0.75 kw	15 T/H	1500 x 1800 MM	1600 KG	2088 x 2719 x 2961



ISO 9001 : 2015
Approval No : 0048394