

# Precleaner

IPMA INDUSTRY SDN. BHD.

益马工业有限公司

198501004398 (136837-P)



with Pre Suction Aspirator and  
Straw Scraper System **Model: SAB-A-S-1500**



## OUTPUT



Grain Output



Large Impurities



Small Impurities



Light Impurities

## OUTSTANDING FEATURES

1. Motorised scrapper to regulate material flow and to reduce blockage of straw on top of screen.
2. Air suction chamber c/w suction blower.
3. Using combination of air and perforated screen for more efficient cleaning.
4. Light impurities are removed by both pre and post aspiration system

[www.ipmaindustry.com](http://www.ipmaindustry.com)

Details provided about the properties and usability of the products are purely for information purposes and do not constitute a guarantee of these characteristics. The extent of goods delivered and services performed is determined by the subject matter of the specific contract. No liability accepted for errors or omissions.

# IPMA

Your One Stop Rice Processing And Solution Centre!



# Technical Specification

## Precleaner with Pre Suction Aspirator and Straw Scraper System

Model: SAB-A-S-1500

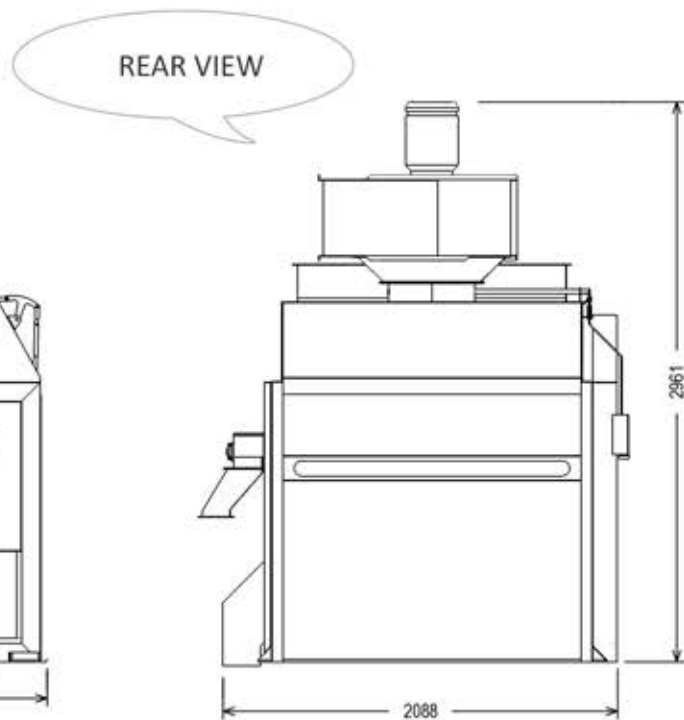
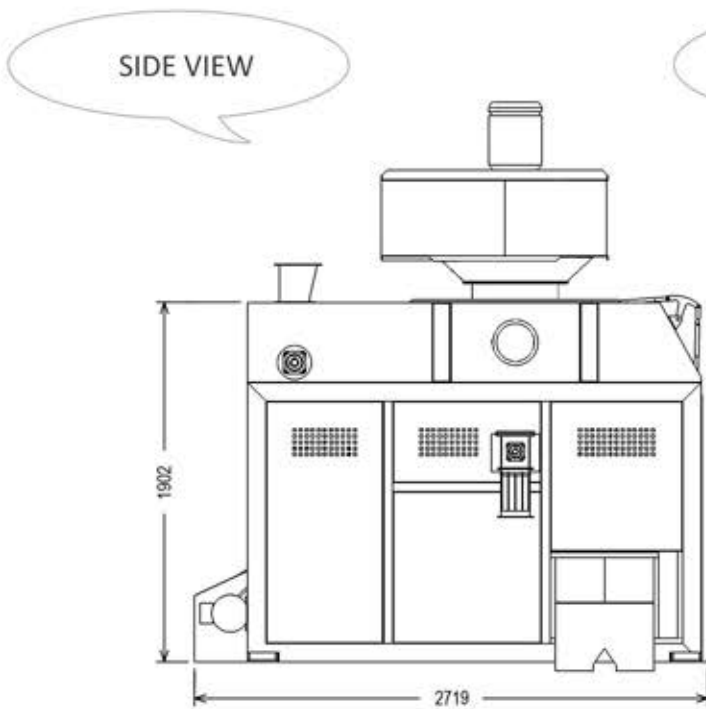
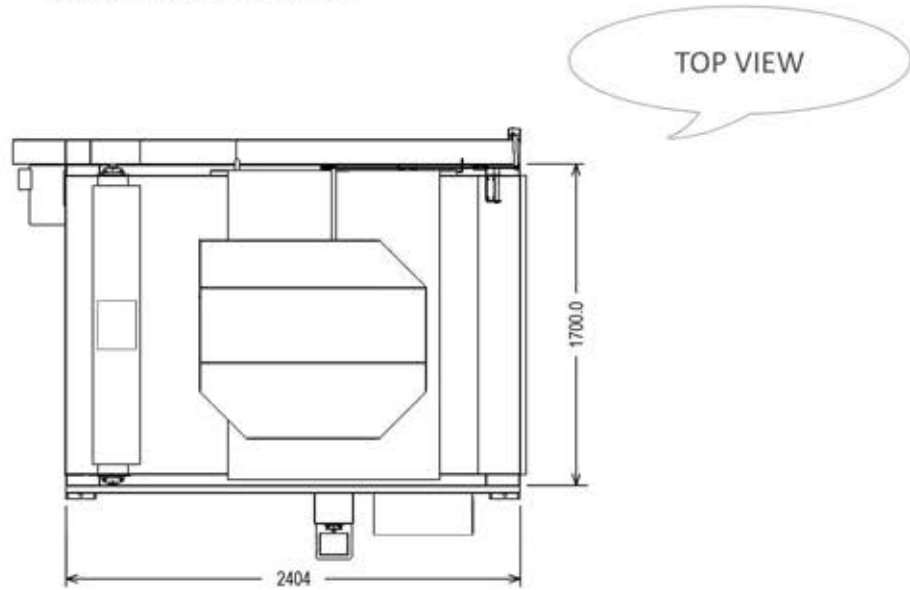

Model	Power Requirement	Capacity	Screen Width 2 layers	Weight	Dimension(MM) (L x W x H)
SAB-A-S-1500	7.5 kw + 1.5 kw + 0.75 kw	15 T/H	1500 x 1800 MM	1600 KG	2088 x 2719 x 2961



ISO 9001 : 2015  
Approval No : 0048394