



Technical Specification

Fully Automatic Packing and Weighing Machine

Model: RPM-100

ISOMETRIC VIEW

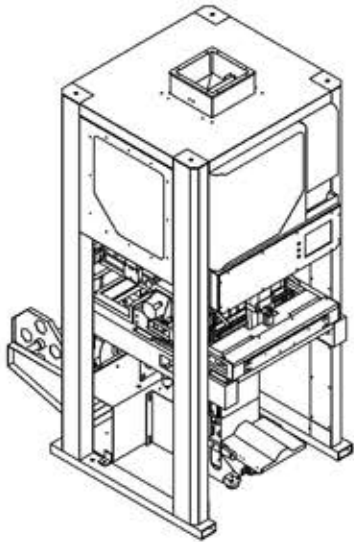

SIDE VIEW

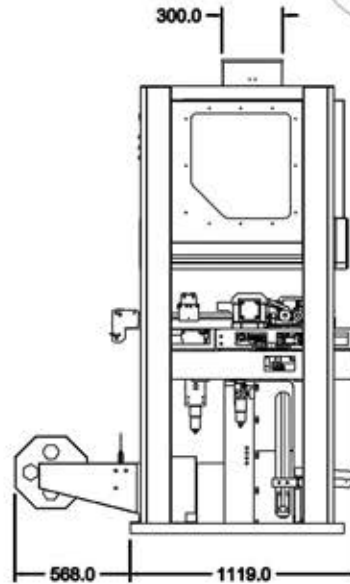

TOP VIEW

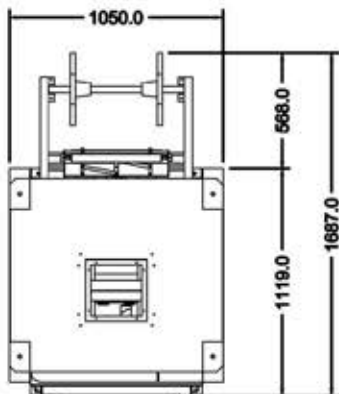

FRONT VIEW

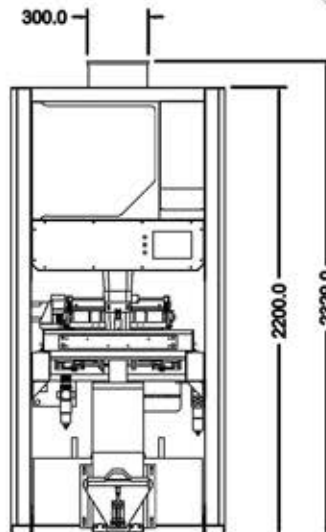

Model	Weighing Range	Output Capacity	Power Requirement	Dimension(MM) (L x W x H)	Voltage	Air Pressure
RPM-100	1-15Kg	400 ~ 480 Bags/Hour	1KW (3Ø 415V)	1687 x 1050 x 2329	415V 50 - 60 Hz	6 Bar



ISO 9001 : 2015
Approval No : 0048394