

Fully Automatic Weighing & Packing Machine

IPMA INDUSTRY SDN. BHD.

益马工业有限公司

198501004398 (138837-P)



Model: RPM-100

SMART MACHINE



[+]

Weighing Indicator
from Japan Unipulse



[+]

Fast & Reliable
Japan Oriental Motor
DC Motor



[+]

User Friendly
Japan Fuji Electric
7" colour Touch
Screen



[+]

Fast & Accurate
Japan SunX
Colour Sensor



[+]

High Quality & Reliable
Pneumatic Parts from
Japan SMC and
Germany Festo



Video

OUTSTANDING FEATURES

1. User friendly touch screen pages(GUI) for parameter settings.
2. Six different operating profiles can be stored.
3. Sensors with advance teach-in function for accurate sensing.
4. Advance DC brushless motor for faster bag feeding.
5. Combination of high quality pneumatic and electronic systems for reliable operation.

www.ipmaindustry.com

Details provided about the properties and usability of the products are purely for information purposes and do not constitute a guarantee of these characteristics. The extent of goods delivered and services performed is determined by the subject matter of the specific contract. No liability accepted for errors or omissions.

IPMA

Your One Stop Rice Processing And Solution Centre!



Technical Specification

Fully Automatic Packing and Weighing Machine

Model: RPM-100

ISOMETRIC VIEW

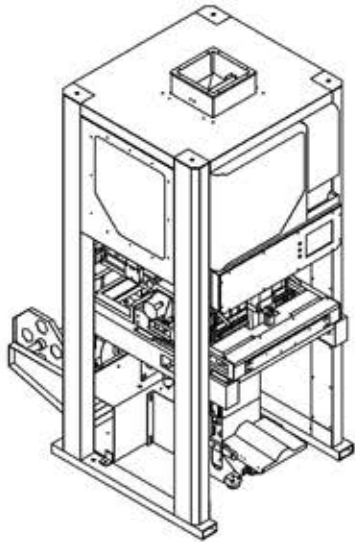

SIDE VIEW

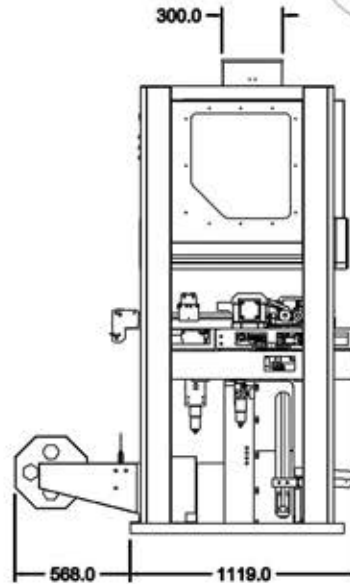

TOP VIEW

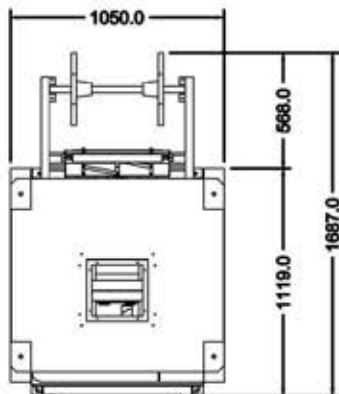

FRONT VIEW

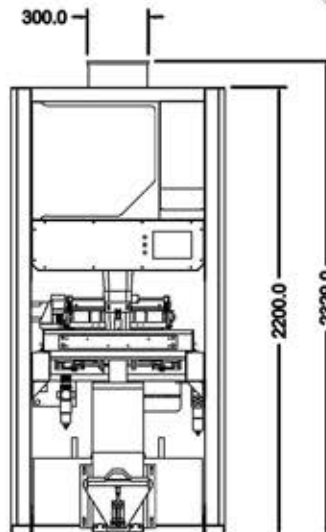

Model	Weighing Range	Output Capacity	Power Requirement	Dimension(MM) (L x W x H)	Voltage	Air Pressure
RPM-100	1-15Kg	400 ~ 480 Bags/Hour	1KW (3Ø 415V)	1687 x 1050 x 2329	415V 50 - 60 Hz	6 Bar

