

# Rice Precleaner

IPMA INDUSTRY SDN. BHD.

益马工业有限公司

198501004398 (136837-P)



Model: SAB-600 / SAB-800 / SAB-1000 / SAB-1250 / SAB-1500



## OUTPUT



Rice



Large Impurities



Small Grain



Dust

[www.ipmaindustry.com](http://www.ipmaindustry.com)

Details provided about the properties and usability of the products are purely for information purposes and do not constitute a guarantee of these characteristics. The extent of goods delivered and services performed is determined by the subject matter of the specific contract. No liability accepted for errors or omissions.

# IPMA

Your One Stop Rice Processing And Solution Centre!

# Technical Specification

## Rice Precleaner

Model: SAB-600 / SAB-800 / SAB-1000 / SAB-1250 / SAB-1500

CONSTRUCTION AND FLOW

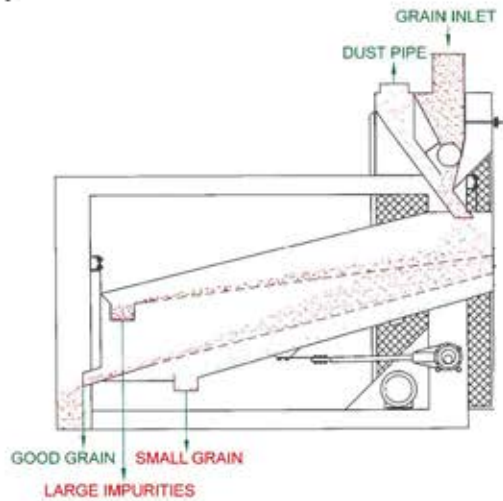

FRONT VIEW

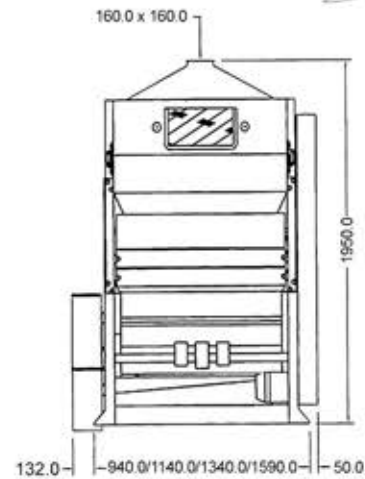

SIDE VIEW

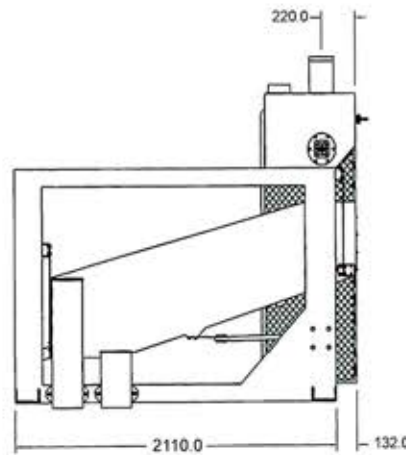

Model	Power Requirement	Output Capacity	Screen Width 2 layers	Weight	Dimension(MM) (L x W x H)
SAB-600	1.1 KW	5 T/H	600 MM	520 KG	2242 x 1122 x 1950
SAB-800	1.1 KW	8 T/H	800 MM	546 KG	2242 x 1322 x 1950
SAB-1000	1.1 KW	10 T/H	1000 MM	600 KG	2242 x 1522 x 1950
SAB-1250	1.5 KW	12 T/H	1250 MM	670 KG	2242 x 1772 x 1950
SAB-1500	1.5 KW	15 T/H	1500 MM	1600 KG	2242 x 2022 x 1950