

# Weighing Machine

IPMA INDUSTRY SDN. BHD.

益马工业有限公司

198501004398 (136837-P)



Semi Auto Packer  
(Twin Type)  
Model: SAP-50-2-CT



Inclined Flat Belt Discharge Conveyor  
(with manual adjustable stand)  
Model : DC-H-I-M-400



Heavy Duty Flat Belt  
Discharge Conveyor  
(with Motorize Scissor Lifting)  
Model : DC-H-400



Model : NP-7A

or



Model : DS-9C

Bag Sewing Machine

[www.ipmaindustry.com](http://www.ipmaindustry.com)

Details provided about the properties and usability of the products are purely for information purposes and do not constitute a guarantee of these characteristics. The extent of goods delivered and services performed is determined by the subject matter of the specific contract. No liability accepted for errors or omissions.



Your One Stop Rice Processing And Solution Centre!

# Technical Specification

## Weighing Machine

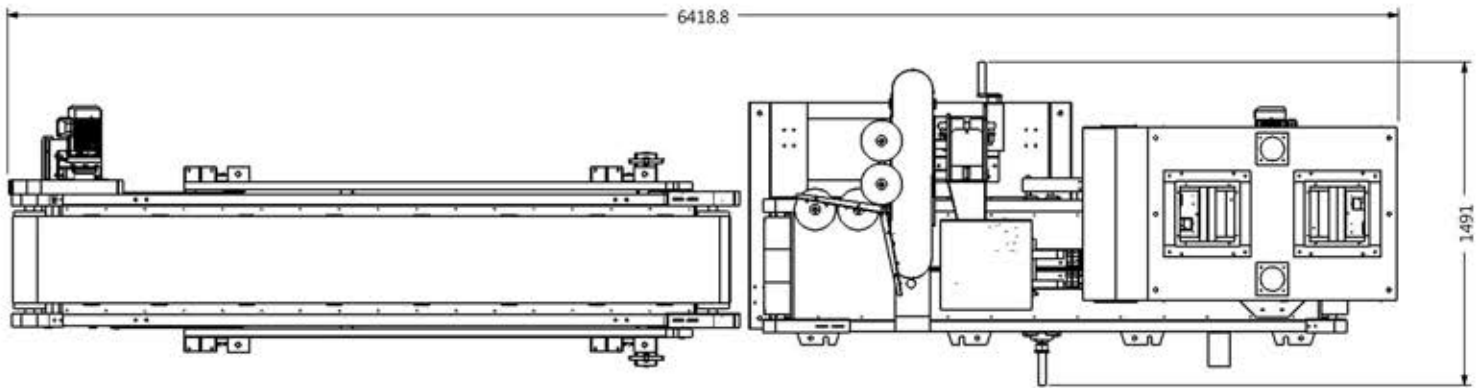

▲ TOP VIEW

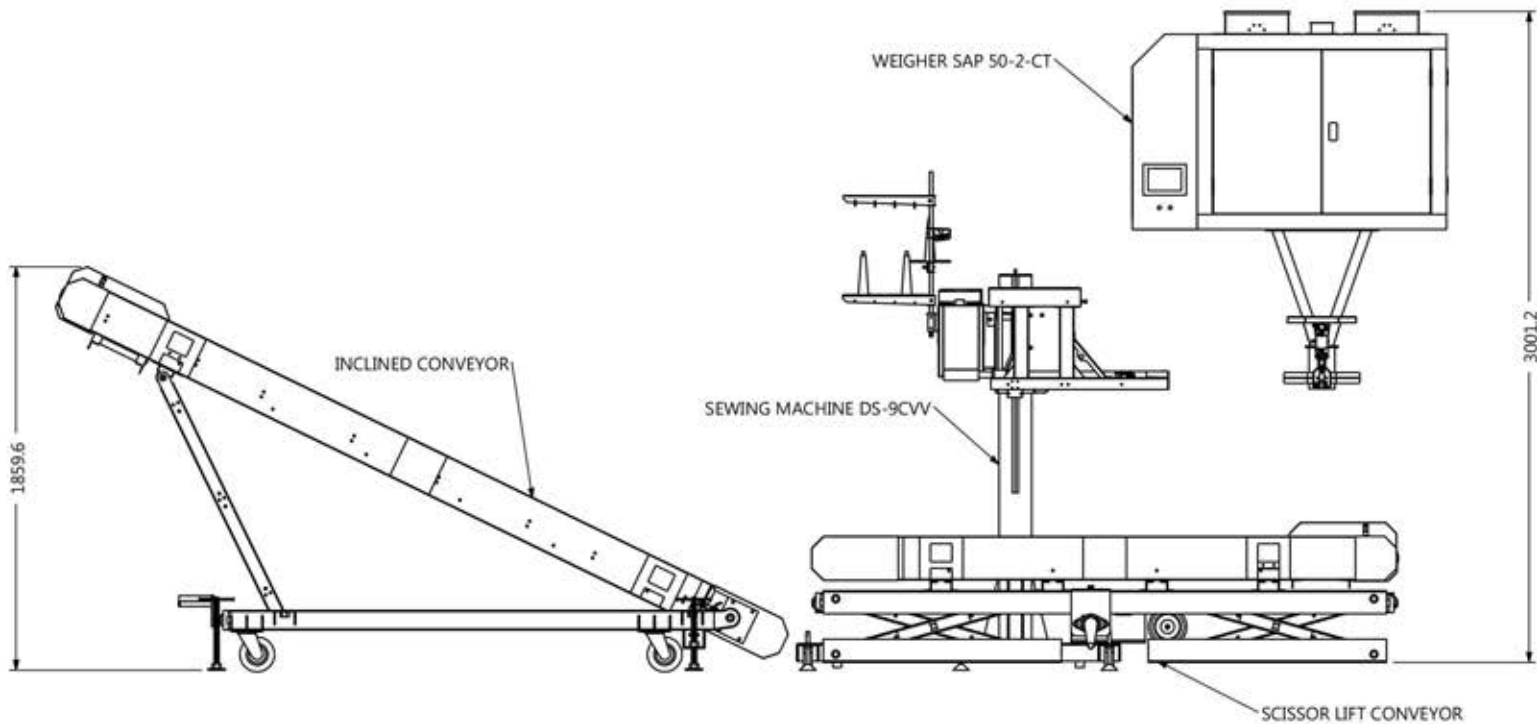

▲ SIDE VIEW

### Semi Auto Packer (Twin Type)

**Model :** SAP-50-2-CT  
**Weighing Range :** 5-50 KG  
**Voltage :** 220V 50-60 Hz  
**Output Capacity :** 8 -10 Bags/min

### Heavy Duty Flat Belt Discharge Conveyor

**Model :** DC-H-400  
**Belting :** 400 mm (Width)  
 Rubber Belt  
**Conveyor Length :** 2694mm

### Inclined Flat Belt Discharge Conveyor

**Model :** DC-H-I-M-400  
**Belting :** 400 mm (Width)  
 Rubber Belt  
**Conveyor Length :** 3701mm

### Bag Sewing Machine

**Model :** SWS-DS-9C  
**Brake Motor :** 4P, 3 Phase,  
 0.75kw or 0.4kw  
**Max Speed :** 2700 rpm  
**Stitch Width :** 7 - 10.5mm  
 (standard setting 10mm)



ISO 9001 : 2015  
 Approval No : 0048394