

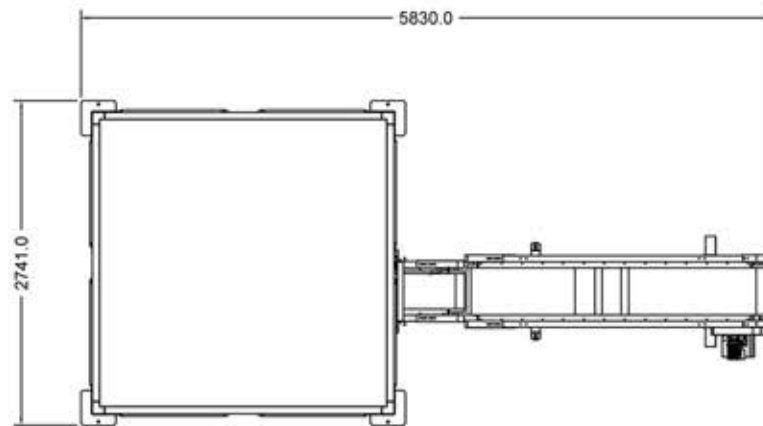

# Technical Specification

## Weighing Machine

TOP VIEW



SIDE VIEW

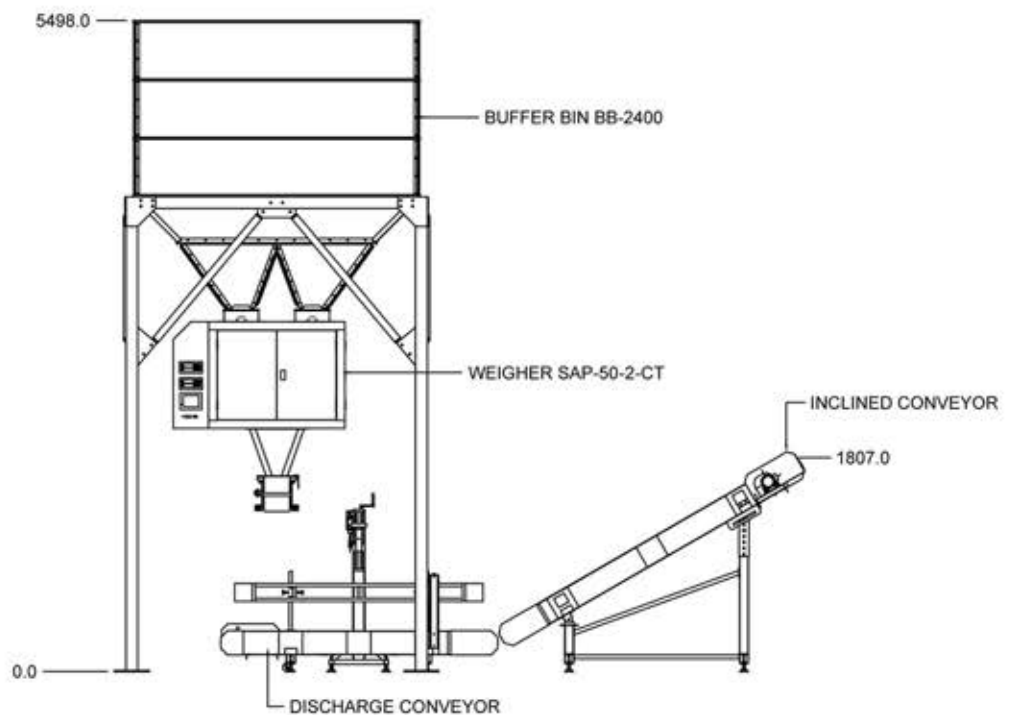

### Semi Auto Packer (Twin Type)

Model : SAP-50-2-CT  
 Weighing Range : 5-50 KG  
 Voltage : 220V 50-60 Hz  
 Output Capacity : 8-10 Bags/min

### Heavy Duty Discharge Belt Conveyor

Model : DC-H-300  
 Belting : 300 mm (Width) Rubber Belt  
 Conveyor Length : 2436mm  
 Weight : 154 KG

### Bag Sewing Machine

Model : SWS-DS-9C  
 Brake Motor : 4P, 3 Phase, 0.75kw or 0.4kw  
 Max Speed : 2700 rpm  
 Stitch Width : 7 - 10.5mm (standard setting 10mm)

